

MICALERT - 303[®]

SENSOR

Microphonic Transducer Sensor Cable



- Economical solution
- Suitable for protection of various types of fences
- Comes in 2000', 1000' and 500' ready to install kits
- Easy to install and maintain

7638 Standish Place
Derwood, MD 20855
Tel: (301) 760-4016 Fax: (301) 762-2253



E-Mail: info@rbtec.com

Website: www.rbtec.com

MICALERT - 303[®]

SENSOR

The **MICALERT-303** sensor is a passive electronic intrusion detection system ideal for the protection of fences, roof-tops and solid walls or for indoor use to protect vaults, strong rooms etc.

MICALERT-303 recognizes motion caused by any attempt to pass through the fence while disregarding nuisance alarms caused by weather conditions or small animals. As a completely modular and user friendly system, **MICALERT-303** is perfectly suited for the DIY, small business, residential and commercial security market.

MICALERT-303 is available in single, dual or multi-zone kits which are easily integrated into RBtec's Command & Control hardware and software packages.

SPECIFICATIONS:

Single/Dual Zone Microcontroller Module (LPU-303).

Operating Power Requirements:

- 12 – 15VDC 40mA @ 12VDC

Lightening Protection:

- Gas Discharge Devices on all Inputs/Outputs & Communication line.

Alarm Outputs:

- Intrusion and Line monitoring output for each zone.
- Dry contact relays with N.O. and N.C. contacts rated 1A @ 12VDC.
- Alarm transmission via Ethernet TCP/IP.
- Alarm transmission via RS-485 Protocol.

Alarm Indicators:

- Power Status LED.
- Alarm Relay Status LED.
- Tamper Indication LED.

Connector:

- F type Coax connection Sensor Cable Inputs for each zone.

Enclosure:

- NEMA 4, IP-65
- 9.5" x 7.5" x 2.75" (24cm x 19.5cm x 7.0cm)
- Weight: 2.2 lbs (1Kg)

Environment:

- Operating Temperature: - 40°F to 221°F (-40°C to 105°C)
- Relative Humidity up to 98% non-condensing.

Microphonic Transducer Sensor Cable & Accessories:

- Maximum length per zone: 1000ft (305m).
- UV resistant two conductor Coaxial Cable
- Diameter: 0.118" (3mm).
- Color: Black
- UV resistant cable ties (610 per Zone)

Options:

- Lantronix: Micro100 Ethernet Connection - TCP/IP Protocol.
- RS485: Intrudalert 5500 Protocol.
- VX-25: Weather Compensation Unit (for Multi-Zone Installation).
- Armored Conduit: Vandal Resistant.
- Audio jack module.

Packaging:

- 1,000ft/500ft (305/152m) 9.44'x11.41'x11.81' (24x90x30cm)

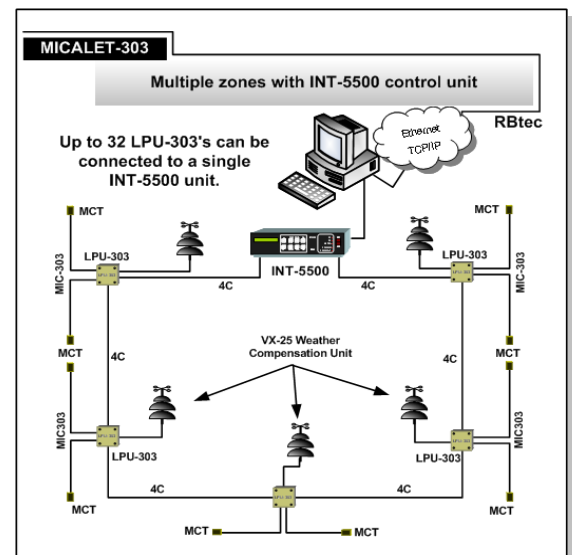
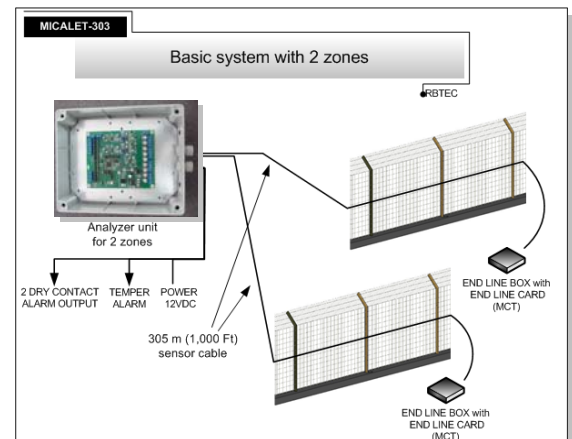
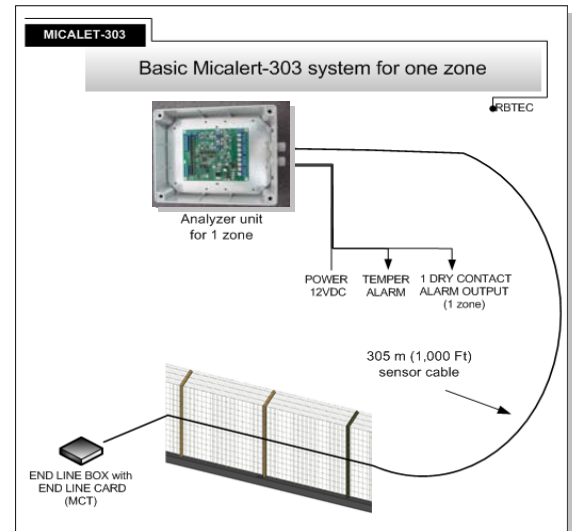

In keeping with our policy of continuous development we reserve the right to alter these specifications without notice.